

CSTA Switch Simulator

User's Guide

Order Number: 05-0994-001

Revision Information: This is a new manual

Software/Version: CSTA Switch Simulator Version 1.0

Copyright © Dialogic Corporation 1997

All contents of this document are subject to change without notice and do not represent a commitment on the part of Dialogic Corporation. Every effort is made to ensure the accuracy of this information. However, due to ongoing product improvements and revisions, Dialogic Corporation cannot guarantee the accuracy of this material, nor can it accept responsibility for errors or omissions. No warranties of any nature are extended by the information contained in these copyrighted materials. Use or implementation of any one of the concepts, applications, or ideas described in this document or on Web pages maintained by Dialogic, may infringe one or more patents or other intellectual property rights owned by third parties. Dialogic does not condone or encourage such infringement. Dialogic makes no warranty with respect to such infringement, nor does Dialogic waive any of its own intellectual property rights which may cover systems implementing one or more of the ideas contained herein. Procurement of appropriate intellectual property rights and licenses is solely the responsibility of the system implementer. The software referred to in this document is provided under a Software License Agreement. Refer to the Software License Agreement for complete details governing use of the software.

Dialogic and the Dialogic logo are registered trademarks, and CT-Connect is a trademark of Dialogic Corporation.

Acrobat and Adobe are registered trademarks of Adobe Systems Incorporated.

Intel and Pentium are registered trademarks of Intel Corporation.

Windows NT is a trademark of Microsoft Corporation.

All other trademarks and registered trademarks are the property of their respective owners.

Date: December 5, 1997

For **Sales Offices** and other contact information, visit our website at <http://www.dialogic.com>.

Contents

About This Manual	v
1 Introduction	
1.1 Overview	1-1
1.2 Features	1-1
1.3 Typical Test Environment	1-2
1.4 Operational Characteristics	1-4
1.4.1 Initialization and Start Up	1-4
1.4.2 Connection to the CTI Server	1-4
1.4.3 CSTA Request Handling	1-4
1.5 Switch Simulator Configuration Scripts	1-5
1.6 Using the Switch Simulator	1-6
2 Installing the Switch Simulator	
2.1 Kit Contents	2-1
2.2 Hardware Requirements	2-1
2.3 Software Requirements	2-2
2.4 Where to Install the Switch Simulator	2-2
2.5 Attaching the Hardware License Key	2-2
2.5.1 Attaching the Hardware License Key to a CTC Server	2-3
2.5.2 Events and Errors	2-3
2.6 Pre-Installation Items	2-3
2.7 Installation Procedure	2-4
2.8 What to Do Next	2-4
2.9 Reading the CTC Test Utility Documentation	2-5
2.10 Changing the TCP/IP Port Number After Installation	2-5
3 Starting the Switch Simulator	
3.1 Overview	3-1
3.2 Starting the Switch Simulator as a Service	3-1
3.3 Starting the Switch Simulator From the Start Menu	3-2
3.4 Starting the Switch Simulator From the Command Line	3-2
4 Event Logging	
4.1 How Switch Simulator Events are Logged	4-1

4.2 Description of Events	4-1
-------------------------------------	-----

A The Switch Configuration Script

A.1 Introduction.	A-1
A.2 Example Switch Configuration Script.	A-1
A.3 Script Construction.	A-6
A.4 Starting the Switch Simulator After Changing a Script.	A-7

B Supported CSTA Services

B.1 Switching Functions	B-1
B.2 Status Reporting.	B-2

C Files Created During Installation

C.1 File Locations and Names	C-1
--	-----

Index

Figures

1.1 The Switch Simulator in a Typical Test Environment.	1-2
1.2 Two Switch Environments Connected with a Trunk.	1-3
2.1 Switch Simulator Hardware License Key	2-2

Tables

4.1 Switch Simulator Events Written to Log	4-1
A.1 Script Constructs Syntax and Description	A-6
B.1 CSTA Switching Function Services	B-1
B.2 CSTA Computing Function Services	B-2
B.3 CSTA Status Reporting Services	B-2
B.4 CSTA Call Event Report Messages	B-3
B.5 CSTA Agent State Event Report Messages.	B-3
C.1 Files Installed	C-1

About This Manual

This manual describes the installation, configuration, and use of Dialogic's CSTA Switch Simulator software.

Audience

This manual is for anyone installing, configuring, or using the CSTA Switch Simulator software as part of an environment for testing Computer Telephony Integration (CTI) servers and applications.

Online Documentation

An online copy of this guide, together with the Adobe® Acrobat® Reader V3.0 software required to read or print the guide, is supplied on the CSTA Switch Simulator CD-ROM.

For details of how to install Acrobat Reader, refer to Section 2.9. For details of the location of the guide, see Appendix C.

Associated Documentation

CTI Server Documentation

Documentation for your CTI server software.

For example, Dialogic's CT-Connect™ (CTC) software is documented in the following:

- *CT-Connect Introduction*
This manual provides an overview of CTC, computer telephony concepts, and telephony application functions.
- *CT-Connect Installation and Administration Guide*
This manual describes how to install, configure, and monitor CTC.
- *CT-Connect Programming Guide*
This manual provides detailed descriptions of the CTC Application Programming Interface (API) routines and guidelines for using these routines.

Test Environment Documentation

Any associated test environment documentation.

For example, Dialogic's CT-Connect test utility, CTC Test, is described in the *CT-Connect Test Utility* guide. An online version of this guide is copied to your system during the CSTA Switch Simulator installation procedure. It describes how to use CTC Test to test the sequence of actions expected of a CTC application against a CTC-supported switch or the CSTA Switch Simulator. For details, see Section 2.9.

Switch Documentation

Refer to the documentation for the switch you are simulating for details of its features and characteristics.

Terms and Definitions

The following terms are used throughout this manual:

Term	Definition
Switch	The CSTA telephony switching device. For example, a Private Branch Exchange (PBX), Private Automatic Branch Exchange (PABX), or central office switch.
Switch Simulator	The CSTA Switch Simulator software.

Conventions

The following conventions are used throughout this manual:

Convention	Meaning
<code>courier</code>	Monospaced type indicates script examples, example screen outputs, and commands you enter.
<i>drive:</i>	Italic (slanted) typeface indicates variable values, placeholders, and function arguments.

Chapter 1: Introduction

1.1: Overview

You use the Switch Simulator to emulate a CSTA Phase II switch environment, including devices such as telephones, trunks, and ACDs. In a CTI network, the Switch Simulator provides you with the framework for building a CTI test environment without switch hardware. Such a test environment can help you to:

- Load test a CTI server
- Develop CTI applications

The Switch Simulator environment is defined by the configuration scripts supplied to you in the Switch Simulator kit. These scripts specify the characteristic functions, events, and behaviors of the CSTA switch and of the devices in the Switch Simulator environment. Appendix A contains more information about configuration scripts.

1.2: Features

The Switch Simulator performs these tasks for you:

- Handles TCP/IP connection requests from the CTI server.
- Processes CSTA service requests from the CTI server, generating switch responses and events.
- Manages event queues for each device, allowing scripted delays in event processing.
- Manages the switch state for each device, ensuring adherence to the characteristics of the device.
- Produces a log file of the switch's actions.

When running, the Switch Simulator also:

- Maintains the device states for all stations, trunks, route points, and ACDs defined.
- Creates and updates a connection list to represent all active calls.
- Outputs data to event logs (if started as a Windows NT™ service).

1.3: Typical Test Environment

You use the Switch Simulator in coordination with other components, including one or more CTI servers, to create a CTI test environment.

Typically, you use CTI applications and CTI test applications to generate and handle your incoming and outgoing calls. These provide the sources and sinks of calls that are then passed by the CTI server to the Switch Simulator for handling.

A CTI test application that supports test scripts can be used to run continuous tests. For example, if you are using a CTC network, you can use CTC Test. This test application supplied with CTC enables you to issue command-line requests or write test scripts. For more information, refer to the *CT-Connect Test Utility* guide. See Section 2.9 for details.

Figure 1.1 shows how the Switch Simulator fits in with other components in a typical CTI test environment.

Figure 1.1: The Switch Simulator in a Typical Test Environment

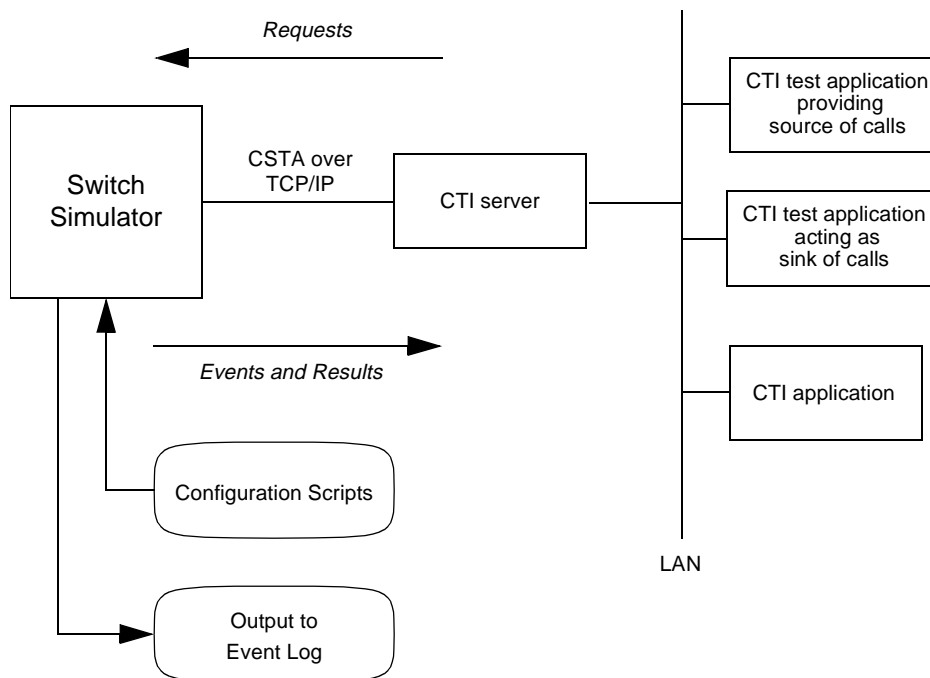

Within the Switch Simulator emulation, two or more switches can connect with one or more trunks, comparable to connecting trunks in loopback on a 'real' switch. The Switch Simulator environment also includes all of the devices involved in a call from its source

to its destination.

Figure 1.2 shows an example test call going over the loopback trunk from one emulated switch environment to another. This illustrates the logical connections and devices involved in a typical test scenario. In this scenario, the CTI application controls devices on one side of the logical switch environment boundary and CTI test scripts control devices on the other side of the logical switch environment boundary.

Figure 1.2: Two Switch Environments Connected with a Trunk

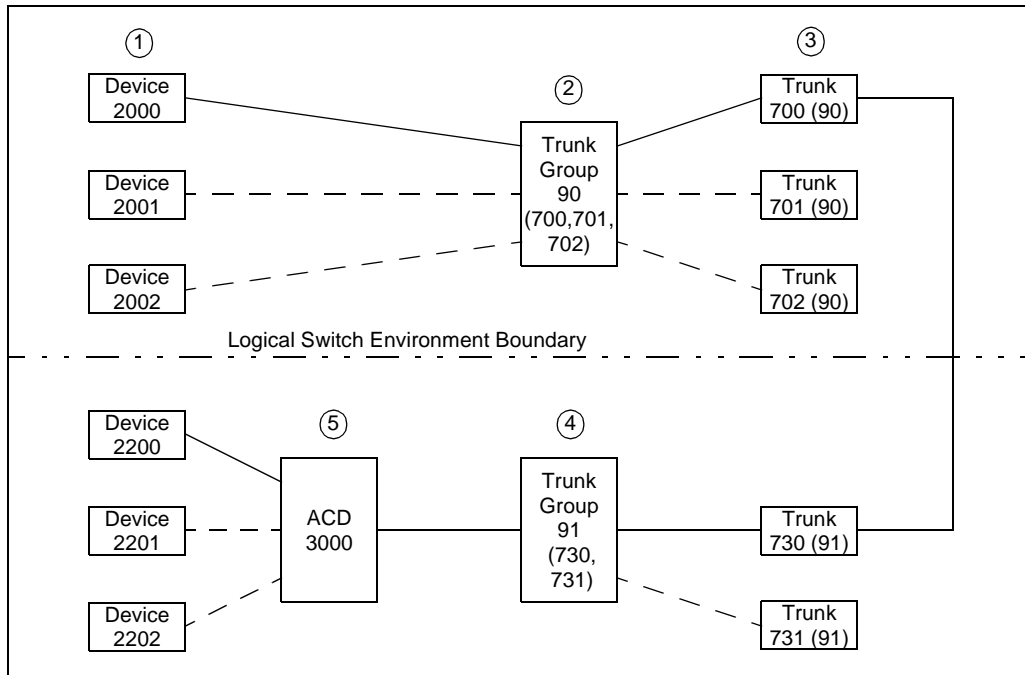

The sequence of the call is:

1. Device 2000 makes a call to 903000 (ACD queue 3000 which is accessed through Trunk Group 90).
2. Trunk Group 90 routes the call to a free trunk (Trunk 700).
3. Trunk 700 requests a trunk from Trunk Group 91, which allocates Trunk 730.
4. Trunk Group 91 routes the call to ACD 3000.
5. ACD 3000 allocates the call to a free device (Device 2200).

1.4: Operational Characteristics

The following sections describe how the Switch Simulator performs its tasks.

1.4.1: Initialization and Start Up

When the Switch Simulator is started, it initializes itself by parsing all of the configuration scripts. During this phase, the Switch Simulator:

- Builds a representation of the defined devices.
- Processes the functions and events referenced.

Then, the Switch Simulator performs a verification to check:

- The validity of all device relationships.
- That each function and event has a definition.

If the Switch Simulator finds errors during start up, it returns details of the errors to help you determine the cause of the problem. The way that it returns these details is dependent on how you run the Switch Simulator:

- If it is started as a Windows NT service (see Section 3.2), it writes errors to the Windows NT Application Event Log. For details of these errors, refer to Section 4.2. These errors are logged if the Switch Simulator cannot continue and has to terminate.
- If it is run as a console application (see Sections 3.3 and 3.4), it logs detailed information, including trace data and errors, to the console window or log file.

1.4.2: Connection to the CTI Server

After starting successfully, the Switch Simulator waits for the CTI server to issue a TCP/IP connection request.

The Switch Simulator supports a maximum of 10 simultaneous connections from CTI servers. After this limit has been reached, connection requests are rejected.

When the TCP/IP connection is made, the Switch Simulator is ready to handle CSTA requests.

1.4.3: CSTA Request Handling

On receipt of a CSTA request, the Switch Simulator:

1. Checks that the specified device exists. If the device does not exist, the Switch Simulator responds with an error message.

2. Examines the device configuration to see if the device supports the requested CSTA operation. If the CSTA operation is not supported, the Switch Simulator responds with an error code assigned to this CSTA operation in the configuration script.
3. Examines the current device state to see if the CSTA operation can be performed. If the CSTA operation cannot be performed, the Switch Simulator responds with an error message.
4. Executes the CSTA operation as defined in the Switch Operations Script. This script is described in Section 1.5.

1.5: Switch Simulator Configuration Scripts

To make the Switch Simulator perform to requirements, its behavior is defined by two configuration scripts:

- The Switch Configuration Script defines:
 - The DNs and other characteristics of all the devices to be simulated, for example, trunks, ACDs, and stations.
 - The relationships between devices, for example, which stations are included in a station group and which trunks are included in a trunk group.

Appendix A includes an example Switch Configuration Script and describes how to edit the script so that it is customized for your test environment.

- The Switch Operation Script defines:
 - The CSTA functionality supported.
 - The type, order, timing of switch actions, events, and results generated for a CSTA function.
 - The use of optional fields within CSTA event and result messages.
 - Miscellaneous configuration and management items.

Dialogic recommends that you do not change the contents of the Switch Operation Script. The supplied script defines operation settings that enable the Switch Simulator to emulate an ECMA-standard CSTA switch. Dialogic offers full support for the Switch Simulator only when it is used with an unchanged Switch Operation Script.

For details of the availability of future scripts that can be used to emulate other switches, contact Dialogic.

The default location for these configuration scripts is:

C:\PROGRAM FILES\DIALOGIC\SWITCHSIM\DATA

File SWITCHSIM.CFG is the Switch Configuration Script. File SCRIPTS.CFG is the Switch Operations Script.

1.6: Using the Switch Simulator

You can start up the Switch Simulator and test it against a CTI application immediately after installation and without editing the configuration scripts. You may want to use it in this way before defining and organizing your complete test environment.

Simply start the Switch Simulator using one of the procedures in Chapter 3, then use your CTI and/or CTI test applications to reference the devices already defined in the Switch Configuration Script. For details, see Appendix A.

Chapter 2: Installing the Switch Simulator

2.1: Kit Contents

Your CSTA Switch Simulator kit contains:

- A CD-ROM containing the software and online documentation.
- A hardware license key. The hardware key licenses your system to use the Switch Simulator (see Section 2.5).
- This manual.

2.2: Hardware Requirements

The hardware required for installing and running the Switch Simulator is as follows:

Hardware	Description
PC platform	An Intel® Pentium®-based machine, or equivalent, suitable for installing Windows NT with: <ul style="list-style-type: none">• At least 20 Mbytes memory• At least 10 Mbytes free disk space (more can be needed for large and complex testing)• A CD-ROM drive• A parallel printer port that can be shared with any required printer connection
Network adapter card	A compatible network adapter card. For details, refer to the <i>Windows NT Hardware Compatibility List</i> provided with your Windows NT documentation. Note that you need a network card even if the Switch Simulator and the CTI server software reside on the same system. Communication between them takes place through a TCP/IP connection, which must be configured to a physical port.

2.3: Software Requirements

The software required for installing and running the Switch Simulator is as follows:

Software	Description
Windows NT Workstation or Windows NT Server	Version 4.0. The Switch Simulator requires TCP/IP to communicate with the CTI server. If you did not install TCP/IP during your Windows NT installation, do so now. For more information, refer to your Windows NT installation documentation.
CTI server	Supports CSTA Phase II links (for example, Version 2.0 of Dialogic's CT-Connect Server software).

2.4: Where to Install the Switch Simulator

Because the CTI server uses TCP/IP to connect to the Switch Simulator, you are free to choose where to install the Switch Simulator software. The Switch Simulator can reside either on the CTI server system or on another networked system as long as it fulfills the hardware and software requirements in Section 2.2 and Section 2.3 respectively.

2.5: Attaching the Hardware License Key

The Switch Simulator uses a hardware license key to check that your system is licensed for running the software. Figure 2.1 shows the hardware key included in the kit.

Figure 2.1: Switch Simulator Hardware License Key

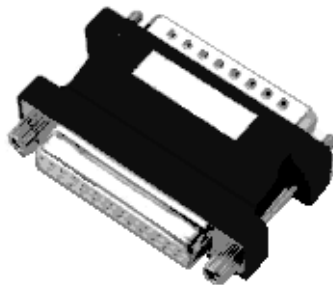

Before starting the installation procedure in Section 2.7, attach the hardware key to the parallel printer port on the system you will use to run the Switch Simulator.

2.5.1: Attaching the Hardware License Key to a CTC Server

If you are installing the Switch Simulator software on a CTC server, it already has a hardware license key attached to the parallel printer port to license use of the CT-Connect software. In this case, attach the Switch Simulator hardware license key (labelled CSTASIM) to the back of the CTC server hardware license key. Both keys can operate together and should not affect use of the port for printer connections.

2.5.2: Events and Errors

After installation, the hardware license key should remain attached to the port. If the key is missing when the Switch Simulator is started, it returns a `cssSwitchSimNoLicenseKey` event or error message. In this case:

1. Stop the Switch Simulator (see Chapter 3).
2. Reattach the hardware license key.
3. Restart the Switch Simulator software (see Chapter 3).

If the Switch Simulator detects a hardware license key but it is the *wrong* key, it returns a `cssSwitchSimWrongKey` event or error message. In this case:

1. Stop the Switch Simulator (see Chapter 3).
2. Attach the key to the parallel printer port, or, if you are using a CTC server, to the CTC server hardware key already attached to the parallel printer port. The Switch Simulator key is labelled CSTASIM.
3. Restart the Switch Simulator software (see Chapter 3).

If the Switch Simulator still returns a `cssSwitchSimWrongKey` event or reports that the password for the key is incorrect, report the problem to Dialogic.

2.6: Pre-Installation Items

Before starting the installation, please go through the following items, gathering any information required:

1. Make sure that you have administrator privileges on the target Windows NT system.
2. Decide where you want the software installed on your system if this will be different from the default location. The default location is:

C:\PROGRAM FILES\DIALOGIC\SWITCHSIM

3. The installation procedure prompts you for the TCP/IP port number for connection with the CTI server and offers port number 7777 as the default. If other software on your Switch Simulator system uses this TCP/IP port, you will need to enter a different port number.

If, after installation, you need to change the port number you specified, follow the procedure in Section 2.8.

4. The installation procedure asks whether you want to install the Switch Simulator as a Windows NT Service. If installed as a Windows NT service:
 - It is started automatically when the system is booted. You can also stop it and start it manually using the procedures in Section 3.2.
 - Switch Simulator errors and events are logged to the Windows NT Application Event Log and can be viewed using Windows NT Event Viewer. For more information, see Chapter 4.

Note: If you decide *not* to install the Switch Simulator software as a Windows NT service, you cannot configure the software later so that it starts as a service. You will need to reinstall.

2.7: Installation Procedure

Follow these steps to install the Switch Simulator:

1. Start the system and log on as administrator.
2. Insert the CD-ROM into its drive.
3. Select Run from the Start menu and enter:

```
drive: \SETUP
```

where *drive*: is the name of the CD-ROM drive. For example: D:\SETUP.

4. Follow the on-screen prompts to set up the Switch Simulator.

The installation creates a Switch Simulator Program Group containing the Switch Simulator icon and the Readme release notes icon. Dialogic recommend that you click on the Readme icon now to read the release notes in a text editor.

Appendix C shows the location and names of all files created during the installation.

2.8: What to Do Next

You have now completed the installation and can go ahead and start the Switch

Simulator (see Chapter 3). The remainder of this chapter describes:

- How to read the online copy of the installed *CT-Connect Test Utility* guide. If you are using a CTC server and you want to use CTC Test with the Switch Simulator, you can refer to this guide for details of CTC Test commands and scripts. To print or display the guide, follow the procedure in Section 2.9.
- What to do if you need to change the TCP/IP port number anytime after installation. Refer to Section 2.10 for details.

2.9: Reading the CTC Test Utility Documentation

CTC Test is a test utility supplied with the Dialogic CT-Connect software. If you are using a CTC server, and you want to use CTC Test in your Switch Simulator test environment, you can find details of CTC Test commands in the *CT-Connect Test Utility* guide.

An online version of this guide, along with a copy of Adobe Acrobat Reader V3.0 for reading or printing the guide, is copied to your system during the Switch Simulator installation procedure.

To install Acrobat Reader V3.0 and display the CT-Connect Test Utility guide, complete the following:

1. Run the file:

```
drive: \ directory \DOCS \Ar32e301 .EXE
```

where *drive*: \ *directory* is the drive and directory used for the CSTA Switch Simulator software installation.

2. Open the AcroRd32 application installed by the Acrobat Reader installation procedure.
3. Use the application to open *drive*: \ *directory* \DOCS \CTCTEST.PDF, where *drive*: \ *directory* is the drive and directory used for the Switch Simulator software installation.

2.10: Changing the TCP/IP Port Number After Installation

The Switch Simulator software requires exclusive access to the TCP/IP port for the connection with the CTI server. If other software on your Windows NT system uses the same TCP/IP port number, you need to change the port number used by the Switch Simulator.

You can do this without reinstalling the Switch Simulator software. Follow these steps:

1. Start the registry editor (REGEDT32) in the Windows NT system directory. For example:

C:\WINNT\SYSTEM32\REGEDT.EXE

2. In the HKEY_LOCAL_MACHINE window, select options:

SOFTWARE

→ Dialogic

→ Switch Simulator

→ Parameters

The CSTAPort setting displayed in the right-hand section of the registry editor window specifies the TCP/IP port number.

3. Double-click on the CSTAPort entry. The String Editor box displays the value defined for the TCP/IP port number.
4. Change the TCP/IP port number to the new port number you require.
5. Click on the OK button and exit the registry editor.

Chapter 3: Starting the Switch Simulator

3.1: Overview

When you start the Switch Simulator software, it initializes by parsing the configuration scripts and checking for errors. If there are no errors severe enough to prevent the Switch Simulator starting, the software begins to run and waits for connection requests from the CTI server.

Sections 3.2 to 3.4 describe the different ways in which you can start and stop the Switch Simulator software.

3.2: Starting the Switch Simulator as a Service

If the Switch Simulator software is installed as a Windows NT service (see Section 2.6), it will start automatically when the system is booted. You can also stop and start the Switch Simulator service manually using the following procedures.

Starting

Complete the following:

1. From Control Panel, select and open the Services item.
2. From the Services menu, select SwitchSimulator.
3. Click on the Start button.

Stopping

Complete the following:

1. From Control Panel, select and open the Services item.
2. From the Services menu, select SwitchSimulator.
3. Click on the Stop button.

Events Logged

If the Switch Simulator is started or stopped as a Windows NT service, it writes events to the Windows NT Application Event Log. You can view this log using Windows NT Event Viewer. For details of these events and for more information about using Event Viewer, refer to Chapter 4.

3.3: Starting the Switch Simulator From the Start Menu

Starting

Complete the following:

1. Click on the Start menu
2. Select Programs → Dialogic → SwitchSim

This starts the Switch Simulator as a console application in an MS-DOS Command Prompt window. On startup, it displays messages to inform you of its progress as it parses the configuration scripts.

Stopping

To stop the Switch Simulator, enter CTRL/C.

3.4: Starting the Switch Simulator From the Command Line

Starting

Complete the following:

1. Click on the Start menu.
2. Select Programs → MS-DOS Command Prompt.
3. Change directory to the location of the Switch Simulator files and use one of the following methods to start the Switch Simulator:
 - To display startup messages, event and trace information on screen, enter:

```
switchsim -c
```

On startup, the Switch Simulator displays messages to inform you of its progress as it parses the configuration scripts.

- To record event and trace information in a log file rather than on screen, enter:

```
switchsim -c > logfile
```

where *logfile* is the name of the log file.

On startup, the Switch Simulator writes messages to the file to inform you of its progress as it parses the configuration scripts.

Note that event and trace information will continue to be written to the log file, and the file will increase in size, until you stop the Switch Simulator. Make sure that you have sufficient disk space on your system to allow for this.

Stopping

To stop the Switch Simulator, enter CTRL/C.

Chapter 4: Event Logging

4.1: How Switch Simulator Events are Logged

If the Switch Simulator is started as a Windows NT service, it logs events in the Windows NT Application Event Log.

To view this log, you must start the Windows NT Event Viewer:

1. Click on the Start menu.
2. Select Programs → Administration Tools → Event Viewer.

For more information about Event Viewer, refer to your Windows NT documentation. For details of how to start the Switch Simulator as a Windows NT service, refer to Section 3.2.

4.2: Description of Events

Table 4.1 lists the events that the Switch Simulator writes to the Windows NT Application Event Log. Note that these events are logged only if the software is started or is running as a Windows NT service.

Table 4.1: Switch Simulator Events Written to Log

Event	Description
cssSwitchSimConfigError	The Switch Simulator has found problems in the switch configuration script. The Switch Simulator will not start and cannot be used until the script is corrected. Examine the log file to determine the reason for the configuration error.
cssSwitchSimConnDown	The TCP/IP connection to the CTI server has been closed or has failed. To re-establish the connection, restart the CTI server software.
cssSwitchSimConnUp	A TCP/IP connection has been established and the Switch Simulator can exchange protocol messages with the CTI server that requested the connection.

Table 4.1: Switch Simulator Events Written to Log (Continued)

Event	Description
cssSwitchSimNoLicenseKey	The hardware license key is not attached to the parallel printer port. This key licenses the system to run the Switch Simulator. For details of how to attach the key, refer to Section 2.5.
cssSwitchSimServiceError	An error occurred as the Switch Simulator software attempted to start as a Windows NT service. If you cannot determine the source of the problem, try reinstalling the Switch Simulator. If the problem persists, contact Dialogic.
cssSwitchSimShutdown	The Switch Simulator has shutdown.
cssSwitchSimStarted	The Switch Simulator has started.
cssSwitchSimWrongKey	Either the hardware license key attached to the parallel printer port is not the Switch Simulator hardware license key (labelled CSTASIM) or the key is faulty. For more information, refer to Section 2.5.

Appendix A: The Switch Configuration Script

A.1: Introduction

Section A.2 contains a copy of the Switch Configuration Script supplied with the Switch Simulator. Read this to get a detailed understanding of the devices simulated in your Switch Simulator environment and their relationships.

Section A.3 gives guidance on the construction of the configuration scripts. Refer to this section to edit the Switch Configuration Script.

Because of the specialized knowledge required, Dialogic recommends caution if you intend to modify the Switch Operations Script. For more information, contact Dialogic.

A.2: Example Switch Configuration Script

```
//*****//
//                               DEVICE DEFINITIONS FILE                               //
//*****//
//
// DIALOGIC TELECOM - 11/09/97 - SwitchSim.cfg                                     //
//
// This file contains scripts that define the devices to be simulated by           //
// the switch simulator. It does not specify the switch behavior,                 //
// although some aspects of device behavior can be configured.                   //
//
//*****//
//*****//
//                               DEVICE DEFINITION NOTES                               //
//*****//
//
// Each device definition should specify a device class and device                 //
// type. These are returned in response to the initial query device               //
// sent by the CT server during the assign operation.                             //
//
// Set deviceClass to:                                                            //
// 128 for voice, 64 for data, 32 for image, 8 for audio, 16 for other            //
//
// Set the deviceType to:                                                         //
// 0 for station,      1 for line,          2 for button,                         //
// 3 for ACD,          4 for trunk,         5 for operator,                       //
// 6 for other,        7 for conf bridge,   16 for station group                 //
// 17 for line group,  18 for button group, 19 for ACD group                    //
// 20 for trunk group, 21 for operator group, 22 for parking device,             //
// 255 for other group                                                            //
```



```

deviceType    = 6
deviceClass   = 128

// Add a route point (DN 6001) to the device set for the switch simulator.
// If a route is not selected within RouteWaitTime (mS), then the call
// will be directed to the DefaultDest device.

[Device RoutePoint]
DeviceID      = 6001
ScriptSet     = DefaultRoutePointScriptSet
DefaultDest   = 2001
RouteWaitTime = 3000
deviceType    = 6
deviceClass   = 128

//*****//
//                               ACD DEVICE DEFINITIONS                               //
//*****//

// Add two ACDs (DNs 400 & 401) to the device set for the Switch Simulator.
// The behavior of the ACD is defined by the DefaultACDScriptSet
// Agents are added to the ACDs by logging in with a group ID of 400 or 401
// NoAgentsAction - specifies what to do with calls if no agents are logged
//                  in. Set "Queue" queues calls awaiting agent login;
//                  "fail" rejects calls
// QueueAllCalls  - enables queued events even if agent is available when
//                  call arrives
// AutoRedistDelay - (in mS) delay before which an unanswered call is redirected
//                  back to the queue for redistribution. Set to 0 to disable.
// MaxCallsInQueue - maximum number of calls that can be held in queue; inbound
//                  calls to ACD will fail if queue full.
// CancelPredCallDelay - period (in mS) after which unanswered predictive
//                  calls will be cleared (defaults to 20 secs)

[Device ACD]
DeviceID      = 400-401
ScriptSet     = DefaultACDScriptSet
MaxCallsInQueue = 10
NoAgentsAction = Queue
QueueAllCalls  = ENABLE
AutoRedistDelay = 20000
deviceType    = 3
deviceClass   = 128
CancelPredCallDelay = 15000

//*****//
//                               DIGITAL TRUNK EMULATION DEVICE DEFINITIONS                               //
//*****//

// Add a Trunk Group (DN 80) to the device set for the Switch Simulator.
// This trunk group is selected for outbound calls using the access digits 80.
// The members of the trunk group are Trunks 700 to 749 inclusive and the
// behavior of the trunk group is defined by the DefaultTrunkGroupScriptSet.
// The destination for the outbound calls is the trunk or trunk group with a
// DN of 90.

[Device TrunkGroup]
DeviceID      = 80
Members       = 700-749
Destination   = 90
ScriptSet     = DefaultTrunkGroupScriptSet
deviceType    = 20
deviceClass   = 128

// Add a Trunk Group (DN 90) to the device set for the Switch Simulator.
// This trunk group is selected for outbound calls using the access digits 90.

```

```

// The members of the trunk group are Trunks 750 to 799 inclusive and the
// behavior of the trunk group is defined by the DefaultTrunkGroupScriptSet.
// The destination for the outbound calls is the trunk or trunk group with a
// DN of 80.

[Device TrunkGroup]
DeviceID      = 90
Members       = 750-799
Destination   = 80
ScriptSet     = DefaultTrunkGroupScriptSet
deviceType    = 20
deviceClass   = 128

// Add a series of Trunks (DNs 700-799 inclusive) to the device set for the
// switch simulator. These trunks are allocated to the two trunk groups
// defined above and may not be used directly since their destinations are
// defined by the trunk group.
//
// There are a large number of config items which allow the trunk(s) to be
// configured to emulate analogue or digital trunks (ENABLE / DISABLE):
//
// TX_OLI      : Send Originating Line ID
// TX_DNIS     : Send Dialed Number
// TX_APTY     : Send Answering Party
// TX_RPTY     : Send Releasing Party
// RX_OLI      : Receive Originating Line ID
// RX_DNIS     : Receive Dialed Number
// RX_APTY     : Receive Answering Party
// RX_RPTY     : Receive Releasing Party
// TX_DeliverEvent : Send Delivered Signal to other trunk
// TX_AnswerEvent  : Send Answered Signal to other trunk
// TX_OrigPtyClrEvent : Send Originating Party Cleared Signal to other trunk
// TX_ClldPtyClrEvent : Send Called Party Cleared Signal to other trunk
// RX_DeliverEvent : Receive Delivered Signal from other trunk
// RX_AnswerEvent  : Receive Answered Signal from other trunk
// RX_OrigPtyClrEvent : Receive Originating Party Cleared Signal from other
// trunk
// RX_ClldPtyClrEvent : Receive Called Party Cleared Signal from other trunk

[Device Trunk]
DeviceID      = 700-799
ScriptSet     = DefaultTrunkScriptSet
deviceType    = 4
deviceClass   = 128
TX_OLI        = ENABLE
TX_DNIS       = ENABLE
TX_APTY       = ENABLE
TX_RPTY       = ENABLE
RX_OLI        = ENABLE
RX_DNIS       = ENABLE
RX_APTY       = ENABLE
RX_RPTY       = ENABLE
TX_DeliverEvent = ENABLE
TX_AnswerEvent  = ENABLE
TX_OrigPtyClrEvent = ENABLE
TX_ClldPtyClrEvent = ENABLE
RX_DeliverEvent = ENABLE
RX_AnswerEvent  = ENABLE
RX_OrigPtyClrEvent = ENABLE
RX_ClldPtyClrEvent = ENABLE

//*****//
//          ANALOGUE TRUNK EMULATION DEVICE DEFINITIONS          //
//*****//

// Add a Trunk Group (DN 81) to the device set for the Switch Simulator.

```

```

// This trunk group is selected for outbound calls using the access digits 81.
// The members of the trunk group are Trunks 800 to 749 inclusive and the
// behavior of the trunk group is defined by the DefaultTrunkGroupScriptSet.
// The destination for the outbound calls is the trunk or trunk group with a
// DN of 91.

[Device TrunkGroup]
DeviceID      = 81
Members      = 800-849
Destination  = 91
ScriptSet    = DefaultTrunkGroupScriptSet
deviceType   = 20
deviceClass  = 128

// Add a Trunk Group (DN 91) to the device set for the Switch Simulator.
// This trunk group is selected for outbound calls using the access digits 91.
// The members of the trunk group are Trunks 850 to 899 inclusive and the
// behavior of the trunk group is defined by the DefaultTrunkGroupScriptSet.
// The destination for the outbound calls is the trunk or trunk group with a
// DN of 81.

[Device TrunkGroup]
DeviceID      = 91
Members      = 850-899
Destination  = 81
ScriptSet    = DefaultTrunkGroupScriptSet
deviceType   = 20
deviceClass  = 128

// Add a series of Trunks (DNs 800-799 inclusive) to the device set for the
// switch simulator. These trunks are allocated to the two trunk groups
// defined above and may not be used directly since their destinations are
// defined by the trunk group.
//
// There are a large number of config items which allow the trunk(s) to be
// configured to emulate analogue or digital trunks (ENABLE / DISABLE) :
//
// TX_OLI           : Send Originating Line ID
// TX_DNIS          : Send Dialed Number
// TX_APTY          : Send Answering Party
// TX_RPTY          : Send Releasing Party
// RX_OLI           : Receive Originating Line ID
// RX_DNIS          : Receive Dialed Number
// RX_APTY          : Receive Answering Party
// RX_RPTY          : Receive Releasing Party
// TX_DeliverEvent  : Send Delivered Signal to other trunk
// TX_AnswerEvent   : Send Answered Signal to other trunk
// TX_OrigPtyClrEvent : Send Originating Party Cleared Signal to other trunk
// TX_ClldPtyClrEvent : Send Called Party Cleared Signal to other trunk
// RX_DeliverEvent  : Receive Delivered Signal from other trunk
// RX_AnswerEvent   : Receive Answered Signal from other trunk
// RX_OrigPtyClrEvent : Receive Originating Party Cleared Signal from other
// trunk
// RX_ClldPtyClrEvent : Receive Called Party Cleared Signal from other trunk

[Device Trunk]
DeviceID      = 800-899
ScriptSet    = AnalogueTrunkScriptSet
deviceType   = 4
deviceClass  = 128
TX_OLI       = DISABLE
TX_DNIS      = DISABLE
TX_APTY      = DISABLE
TX_RPTY      = DISABLE
RX_OLI       = DISABLE
RX_DNIS      = DISABLE
RX_APTY      = DISABLE

```

```

RX_RPTY      = DISABLE
TX_DeliverEvent = DISABLE
TX_AnswerEvent = DISABLE
TX_OrigPtyClrEvent = ENABLE
TX_ClldPtyClrEvent = DISABLE
RX_DeliverEvent = DISABLE
RX_AnswerEvent = DISABLE
RX_OrigPtyClrEvent = ENABLE
RX_ClldPtyClrEvent = DISABLE

```

A.3: Script Construction

As illustrated by the script in Section A.2, script definitions are composed using three constructs. Table A.1 describes the syntax of these constructs.

Table A.1: Script Constructs Syntax and Description

Construct Syntax	Description
[Device <name>]	Marks the start of a device definition. Note: you do not need to mark the end of a script definition. When the parser reaches the start of the next script definition, or the end of file, the previous definition is deemed complete. <name> is either a reserved word for this script type or references a definition in another script. For example, the following marks the start of a script definition for a trunk device: [Device Trunk]
<feature> =<value>	A script definition line. <feature> is what you want to define. <value> is the value you set for the feature. For example, the following defines that a DeviceID value is set to 90: DeviceID = 90
//	Marks the start of a comment line. The parser ignores all characters between this point and the end of the line. For example, the following is a comment to note that the next line will add an ACD: // Add an ACD to the Device set

The Switch Configuration Script contains numerous [Device...] entries defining all of the devices required and their groupings.

Here is an example [Device...] definition:

```

[Device Station]
DeviceID      = 201-209,211
AutoAnswer    = ON
AutoAnswerDelay = 100
ScriptSet     = DefaultStationScriptSet

```

Description:

- This script adds station devices to the Switch Simulator environment.
- The individual stations have DNs of 201 to 209 inclusive, and 211.
- Automatic answering is enabled on stations in this group of DNs and the associated AutoAnswerDelay is set to 100 milliseconds.
- Station behavior for the specified devices is determined by the default DefaultStationScriptSet. This is defined in the Switch Operations Script.

A.4: Starting the Switch Simulator After Changing a Script

After making changes to the Switch Simulator scripts, Dialogic recommends that you start up the Switch Simulator as a console application (see Sections 3.3 and 3.4). The information that the Switch Simulator returns to the console window or console log file is more detailed than the event data returned when it is run as a Windows NT service. This additional information may help you to locate any errors or isolate problems.

Appendix B: Supported CSTA Services

This appendix summarizes the CSTA services supported by the Switch Simulator, maps them to their CT-Connect API equivalents, and describes their purpose.

B.1: Switching Functions

Table B.1: CSTA Switching Function Services

CSTA Service	CT-Connect API Routine	Description
Alternate Call	ctcSwapWithHeld	Place active party on hold
Answer Call	ctcAnswerCall	Answer a call at a device
Associate Data	ctcAssociateData	Store on the switch data that is associated with a call
Call Completion	ctcRespondToInactive	Respond with camp-on, barge-in, or ringback when a call is unanswered
Clear Connection	ctcHangupCall ctcCancelCall	Release the call at a device
Conference Call	ctcConferenceCall	Bring new party into a conference
Consultation Call	ctcConsultationCall	Put current call on hold and dials a consultation call
Divert Call	ctcPickupCall ctcDeflectCall	Pick-up a call ringing at another device Redirect an alerting call
Escape [†]	ctcCstaEscape	Enable exchange of private data with the switch
Hold Call	ctcHoldCall	Put a call on hold
Make Call	ctcMakeCall	Make a normal call from a device
Make Predictive Call	ctcMakePredictiveCall	Originate a call on behalf of a user or group.
Query Device	ctcGetAgentStatus ctcGetMessageWaiting ctcGetDoNotDisturb ctcAssign	Query agent status and work mode Query message lamp Query do-not-disturb Used on assign to check DN validity

Table B.1: CSTA Switching Function Services (Continued)

CSTA Service	CT-Connect API Routine	Description
Reconnect Call	ctcReconnectHeld	Disconnect a consultation call and reconnect held party
Retrieve Call	ctcRetrieveCall	Retrieve a held call
SendDTMF Tones†	ctcSendDTMF	Generate DTMF tones over the line
Set Feature	ctcSetAgentStatus ctcSetMessageWaiting ctcSetDoNotDisturb ctcSetCallForward	Set agent status and work mode Set the message lamp Set do-not-disturb Set call-forwarding
Single Step Transfer	ctcSingleStepTransfer	Transfer current call to another number
Transfer Call	ctcTransferCall	Complete a call transfer

†To support development of your application, the Switch Simulator recognizes these calls but does not respond with the CSTA-defined functionality

Table B.2: CSTA Computing Function Services

CSTA Service	CT-Connect API Routine	Description
Route End	None. A route request has been received by the CT-Connect server but there is no outstanding ctcGetRouteQuery.	Indicate that call routing is complete.
Route Request	ctcGetRouteQuery.	Request a route for the call.
Route Select	ctcRespondToRouteQuery.	Provide a new route for the call.

B.2: Status Reporting

Table B.3: CSTA Status Reporting Services

CSTA Service	CT-Connect API Routine	Description
Monitor Start	ctcSetMonitor (on)	Request events be sent for a device
Monitor Stop	ctcSetMonitor (off)	Request events be stopped for a device
Snapshot Device	ctcSnapshot	Return information for calls associated with a device

Table B.4: CSTA Call Event Report Messages

CSTA Call Event Report Message	CT-Connect API Event	Description
Call Cleared	ctcK_TpDisconnected	The call has been cleared
Conferenced	ctcK_TpConferenced	The call has joined a conference
Connection Cleared	ctcK_TpDisconnected	The call has been cleared
Delivered	ctcK_InboundCall ctcK_DestSeized	Provides information on inbound and alerting calls
Diverted	ctcK_Diverted	The call has been diverted to another destination
Established	ctcK_TpAnswered ctcK_OpAnswered	The call has been answered
Failed	ctcK_DestBusy ctcK_DestNotObtainable ctcK_Error	The call failed
Held	ctcK_TpSuspended	The call has been held
Network Reached	ctcK_DestSeized	The call has been successfully dialed
Originated	ctcK_Offhook	A new call has been made from the device
Queued	ctcK_InboundCall	A new call has been queued to the device
Retrieved	ctcK_TpRetrieved ctcK_OpRetrieved	The call has been retrieved
Service Initiated	ctcK_Offhook	A new call has been made from the device
Transferred	ctcK_Transferred	The call has been transferred

Table B.5: CSTA Agent State Event Report Messages

CSTA Agent State Event Report Messages	CT-Connect API Events	Description
Agent Busy	ctcK_AgentModeChange	The agent is busy on a call
Agent Logged On	ctcK_AgentLoggedOn	The agent has logged on
Agent Logged Off	ctcK_AgentLoggedOff	The agent has logged off
Agent Not Ready	ctcK_AgentModeChange	The agent is not ready to take calls

Table B.5: CSTA Agent State Event Report Messages (Continued)

CSTA Agent State Event Report Messages	CT-Connect API Events	Description
Agent Ready	ctcK_AgentModeChange	The agent is ready to take calls
Agent Working After Call	ctcK_AgentModeChange	The agent is working on customer details after completing a call

Appendix C: Files Created During Installation

C.1: File Locations and Names

Table C.1 shows the locations and names of the files created during the Switch Simulator installation. In all cases, *drive:\directory* refers to the location where the Switch Simulator files have been installed (the default location is C:\PROGRAM FILES \DIALOGIC\SWITCHSIM).

Table C.1: Files Installed

Location	Filename
<i>drive:\directory\</i>	README.TXT
<i>drive:\directory\BIN</i>	CSTA_SERVICES.DLL MSVCRT.DLL OSSAPI.DLL OSSMEM.DLL EVENTMSG.S.DLL README.ICO SCRIPTS.TMP SOEDBER.DLL SWITCHSIM.EXE SWITCHSIM.ICO SWITCHSIMID.EXE SWITCHSIM.TMP SWITCHSIMULATOR.DLL
<i>drive:\directory\DATA</i>	SCRIPTS.CFG SWITCHSIM.CFG
<i>drive:\directory\DOCS</i>	AR32E301.EXE CSTASIM.PDF CTCTEST.PDF

Index

A

Acrobat Reader
installing, 2-5
Application Event Log, 4-1

C

Computer Telephony Integration
See CTI
Configuration, A-1
Configuration scripts, 1-1, 1-5
constructs syntax, A-6
Device, A-6
example, A-1
how to write, A-6
location, 1-5
parsing, 1-4
types, 1-5
Connections
maximum, 1-4
CSTA requests
handling, 1-4
CSTA services
CT-Connect equivalents, B-1
listed, B-1
CT-Connect
corresponding CSTA Services, B-1
CTC Test, vi, 2-5
CTC Test commands, 2-5
CTC Test scripts, 2-5
CT-Connect Test Utility guide, 2-5
documentation, v
CTI, 1-1
application, 1-2
test script, 1-2

Customizing, 1-1

D

Devices
script, A-6
trunk, 1-2

E

Error codes, 1-4
Event logging, 3-2, 4-1
viewing, 4-1

F

Files installed, C-1

H

Hardware license key, 2-2
attaching, 2-3
attaching to a CTC server, 2-3
cssSwitchSimNoLicenseKey, 2-3
cssSwitchSimWrongKey, 2-3
label, 2-3
password, 2-3
wrong key, 2-3

I

Installation, 2-1
Installed files, C-1

K

Key
See Hardware license key

Kit contents, 2-1

L

License key

 See Hardware license key

Loopback trunk, 1-2

P

Port number

 TCP/IP, 2-4

S

Scripts

 constructs syntax, A-6

 CTI test, 1-2

 Device, A-6

 example, A-1

 how to write, A-6

 parsing, 1-4

Switch Simulator

 as a service, 3-1

 by command line, 3-2

 configuration scripts, 1-1

 configuring, A-1

CSTA services, B-1

 customizing, 1-1

 error codes, 1-4

 event logging, 3-2, 4-1

 features, 1-1

 handling CSTA requests, 1-4

 hardware required, 2-1

 in operation, 1-4

 initialization, 1-4, 3-1

 installing, 2-1

 kit contents, 2-1

 software required, 2-2

 starting, 3-1

 typical test environment, 1-2 to 1-3

T

TCP/IP

 maximum connections, 1-4

 port number, 2-4

Test environment, 1-1

 CTC test utility, vi

 documentation, vi

 illustrated, 1-3

 typical, 1-2 to 1-3

Trace information, 3-3

Trunk, 1-2